



CLICK ANYWHERE FOR MORE DETAILS

MANUAL PREVIEW

Insley

Operator's Manual

JENSALES

purchase full manual at

H

JENSALES.COM

or Call 800-443-0625



CLICK ANYWHERE FOR MORE DETAILS

THIS IS A MANUAL PRODUCED BY JENSALES INC. WITHOUT THE AUTHORIZATION OF
INSLEY OR IT'S SUCCESSORS. INSLEY AND IT'S SUCCESSORS
ARE NOT RESPONSIBLE FOR THE QUALITY OR ACCURACY OF THIS MANUAL.

TRADE MARKS AND TRADE NAMES CONTAINED AND USED HEREIN ARE THOSE OF OTHERS,
AND ARE USED HERE IN A DESCRIPTIVE SENSE TO REFER TO THE PRODUCTS OF OTHERS.

Operator's Manual

IN-O-H



CLICK ANYWHERE FOR MORE DETAILS

INSLEY

HYDRAULIC

TYPE

MANUAL PREVIEW

JENSALES®

purchase full manual at

JENSALES.COM

or Call 800-443-0625

**SERVICE
MANUAL**

and

**OPERATING
INSTRUCTIONS**

CLICK ANYWHERE FOR MORE DETAILS

INSLEY MANUFACTURING CORPORATION

INDIANAPOLIS 6, INDIANA

TYPE H SERVICE MANUAL

CLICK ANYWHERE FOR MORE DETAILS



TYPE H - TRUCK MOUNTED, LEFT-SIDE



TYPE H - CRAWLER MOUNTED, RIGHT-SIDE

CLICK ANYWHERE FOR MORE DETAILS

JENS SALES.COM
or call 800-443-0625

purchase full manual at

MANUAL PREVIEW

JENS SALES®

TYPE H SERVICE MANUAL

INDEX

CLICK ANYWHERE FOR MORE DETAILS

INTRODUCTION:

General Information	Page 1
Parts Ordering Information	Page 1
Starting Instructions	Page 1
Cold Weather Starting	Page 2

SECTION A - MAINTENANCE:

Upper Works Lubrication and Maintenance	Page A-1
Daily Lubrication and Maintenance	Page A-1
Weekly Lubrication and Maintenance	Page A-2
Hook Roller Maintenance	Page A-3
Carbody and Crawler Lubrication	Page A-4,5
Steering Brake Adjustment	Page A-6
Hydraulic Cylinder Maintenance	Page A-7,8

SECTION B - ATTACHMENTS:

Backhoe Attachment	Page B-1
Shovel or Loader Attachment	Page B-2
Outrigger Attachment	Page B-2
Swing Conversion Kit	Page B-3

or Call 800-443-0625

SECTION C - OPERATING PROCEDURES:

Operating The Backhoe	Page C-1,2, 3,4,5
---------------------------------	----------------------

CLICK ANYWHERE FOR MORE DETAILS

TYPE H SERVICE MANUAL

CLICK ANYWHERE FOR MORE DETAILS

SECTION D - HYDRAULIC CIRCUITS, AND TROUBLE SHOOTING:

Hydraulic Circuits - General Information	Page D-2
Swing and Outrigger Circuit	Page D-2, 3
Swing and Steering Circuit	Page D-4
Hoe-Arm Circuit	Page D-5, 6
Boom and Bucket Circuit	Page D-7
Propel Circuit	Page D-8, 9
Trouble Shooting	Page D-21, 22, 23, 24

MANUAL PREVIEW

JENSALES®

purchase full manual at

APPENDIX

JENSALES.COM
or Call 800-443-0625

CLICK ANYWHERE FOR MORE DETAILS

TYPE H SERVICE MANUAL

- 3) Bleed any trapped air from the lower hydraulic tank; two petcocks are provided for this purpose. Air must be bled from the tank any time the tank has been drained and refilled. (Fig. 1)
- 4) Check the condition indicator gage on the hydraulic system filter (K6104). Element should be replaced when the gage registers 25 PSI, or every 300 hours. DO NOT attempt to wash the filter element; replace with H4708.
- 5) Grease control-linkage points sparingly. (Fig. 1.)

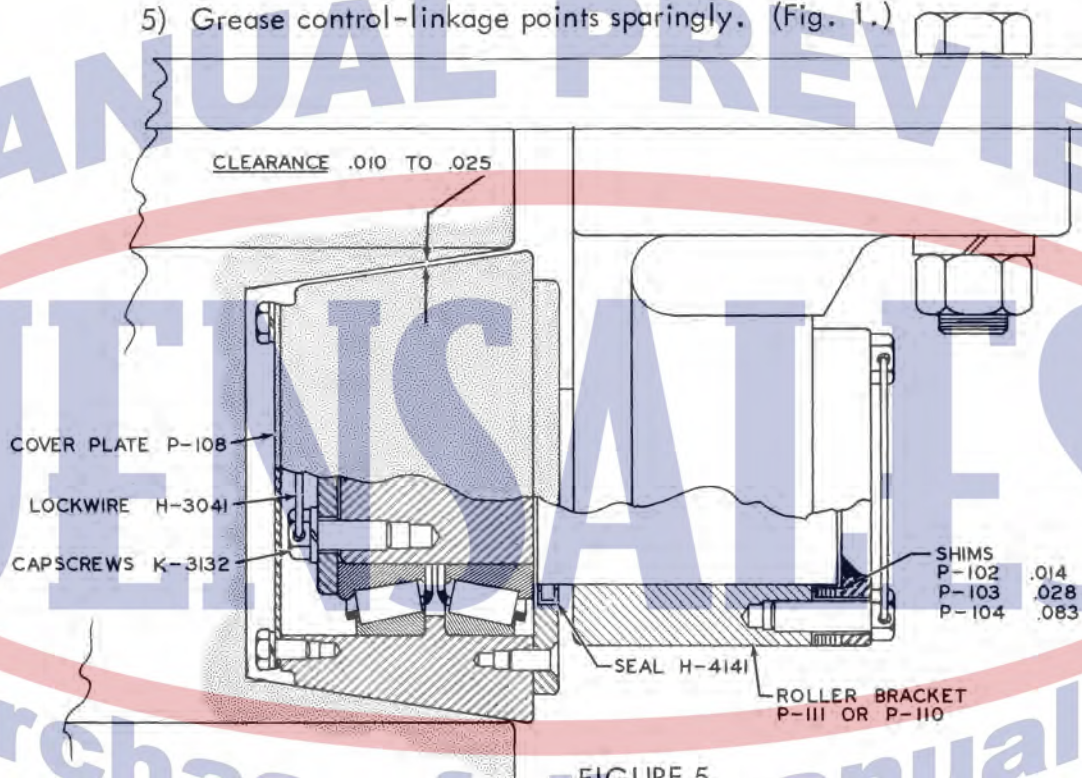

FIGURE 5

TURNTABLE AND HOOK ROLLERS (Fig. 5) Maintenance:

The turntable and the hook rollers require no lubrication as the bearings are pre-packed and sealed at the factory.

Pack and adjust rollers every 1000 hours.

Periodically check the clearance between the roller and the turntable; adjust the roller to maintain .010" to .025" clearance.

Remove shims P102 (.014.), P103 (.028), or P104 (.083) to reduce clearance; add shims to increase.

If a roller appears loose on the roller shaft; readjust bearing preload. Remove roller bracket P110 or P111. Remove cover plate P108, and lock wire H3041. If necessary, remove and repack bearings with a water-proof, heat-resistant bearing grease and replace seal H4141. Tighten cap screws K3132 evenly, until a slight drag (10 in./lb.) is felt on the roller. Replace lock wire H-3041 and cover plate P108. Replace mounting bracket; torque mounting bolts to 450 Ft./Lb. Adjust turntable clearance as outlined above.

TYPE H SERVICE MANUAL

STEERING BRAKE ADJUSTMENT: (Fig. 9.)

The jaw clutch and brake linkage is preset at the factory, and requires no field adjustment. To compensate for lining wear, remove inspection plate and tighten adjusting bolt M-1239, until brake holds. When the brake is properly adjusted, link P208 should clear the band end $\frac{1}{4}$ " at point "A" when brake is set.

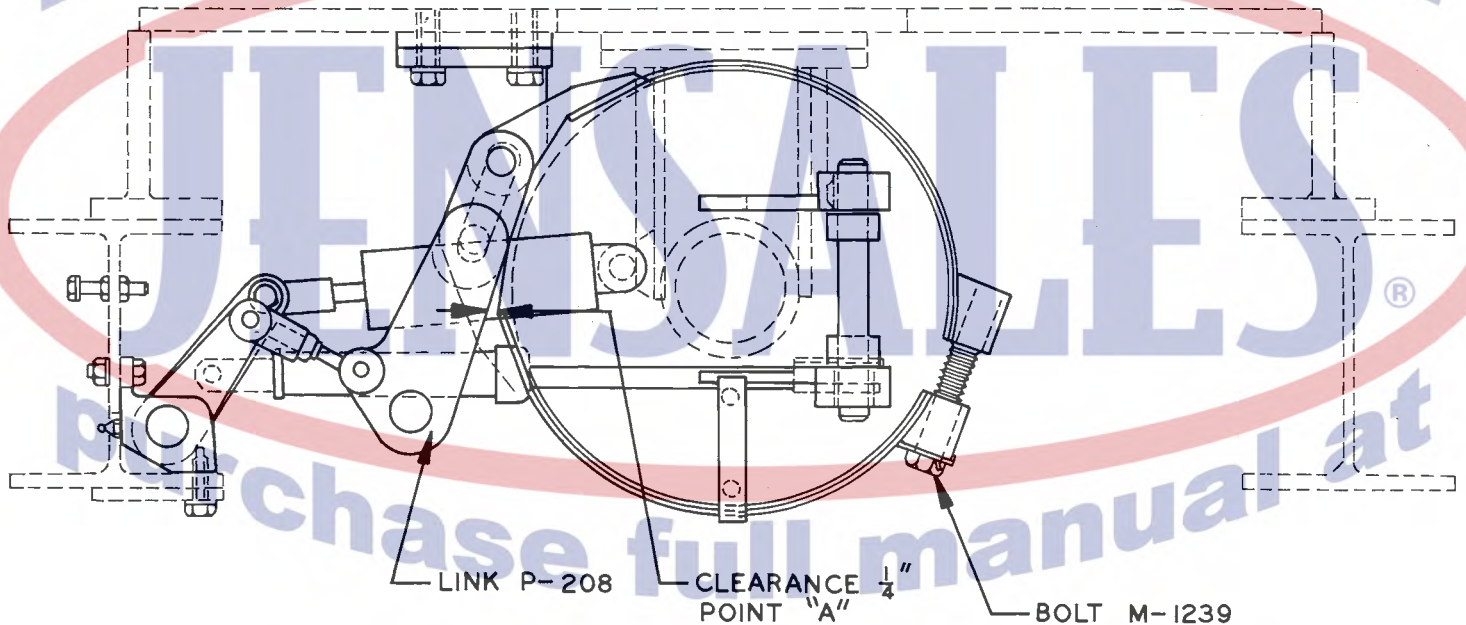

FIGURE 9

JENSALES.COM
or Call 800-443-0625

CLICK ANYWHERE FOR MORE DETAILS